

- energy, each in kJ. For each quantity, kinetic energy and potential energy, specify your choice of datum and reference value at that datum. Let $g = 9.81 \text{ m/s}^2$.
- 2.9 Vehicle crumple zones are designed to absorb energy during an impact by deforming to reduce transfer of energy to occupants. How much kinetic energy, in Btu, must a crumple zone absorb to fully protect occupants in a 3000-lb vehicle that suddenly decelerates from 10 mph to 0 mph?
- 2.10 An object whose mass is 300 lb experiences changes in its kinetic and potential energies owing to the action of a resultant force \mathbf{R} . The work done on the object by the resultant force is 140 Btu. There are no other interactions between the object and its surroundings. If the object's elevation increases by 100 ft and its final velocity is 200 ft/s, what is its initial velocity, in ft/s? Let $g = 32.2 \text{ ft/s}^2$.
- 2.11 A disk-shaped flywheel, of uniform density ρ , outer radius R , and thickness w , rotates with an angular velocity ω , in rad/s.
- (a) Show that the moment of inertia, $I = \int_{\text{vol}} \rho r^2 dV$, can be expressed as $I = \pi \rho w R^4 / 2$ and the kinetic energy can be expressed as $\text{KE} = I \omega^2 / 2$.
- (b) For a steel flywheel rotating at 3000 RPM, determine the kinetic energy, in $\text{N} \cdot \text{m}$, and the mass, in kg, if $R = 0.38 \text{ m}$ and $w = 0.025 \text{ m}$.
- (c) Determine the radius, in m, and the mass, in kg, of an aluminum flywheel having the same width, angular velocity, and kinetic energy as in part (b).
- 2.12 Using $\text{KE} = I \omega^2 / 2$ from Problem 2.11a, how fast would a flywheel whose moment of inertia is $200 \text{ lb} \cdot \text{ft}^2$ have to spin, in RPM, to store an amount of kinetic energy equivalent to the potential energy of a 100 lb mass raised to an elevation of 30 ft above the surface of the earth? Let $g = 32.2 \text{ ft/s}^2$.
- 2.13 Two objects having different masses are propelled vertically from the surface of Earth, each with the same initial velocities. Assuming the objects are acted upon only by the force of gravity, show that they reach zero velocity at the same height.
- 2.14 An object whose mass is 100 lb falls freely under the influence of gravity from an initial elevation of 600 ft above the surface of Earth. The initial velocity is downward with a magnitude of 50 ft/s. The effect of air resistance is negligible. Determine the velocity, in ft/s, of the object just before it strikes Earth. Assume $g = 31.5 \text{ ft/s}^2$.
- 2.15 During the packaging process, a can of soda of mass 0.4 kg moves down a surface inclined 20° relative to the horizontal, as shown in Fig. P2.15. The can is acted upon by a constant force \mathbf{R} parallel to the incline and by the force of gravity. The magnitude of the constant force \mathbf{R} is 0.05 N. Ignoring friction between the can and the inclined surface, determine the can's change in kinetic energy, in J, and whether it is *increasing* or *decreasing*. If friction between the can and the inclined surface were significant, what effect would that have on the value of the change in kinetic energy? Let $g = 9.8 \text{ m/s}^2$.
- 2.16 Beginning from rest, an object of mass 200 kg slides down a 10-m-long ramp. The ramp is inclined at an angle of 40° from the horizontal. If air resistance and friction between the object and the ramp are negligible, determine the velocity of the object, in m/s, at the bottom of the ramp. Let $g = 9.81 \text{ m/s}^2$.
- 2.17 Jack, who weighs 150 lbf, runs 5 miles in 43 minutes on a treadmill set at a one-degree incline (Fig. P2.17). The treadmill display shows he has *burned* 620 kcal. For Jack to break even calorie-wise, how much vanilla ice cream, in cups, may he have after his workout?

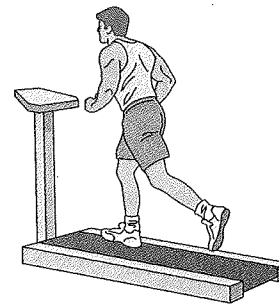

Fig. P2.17

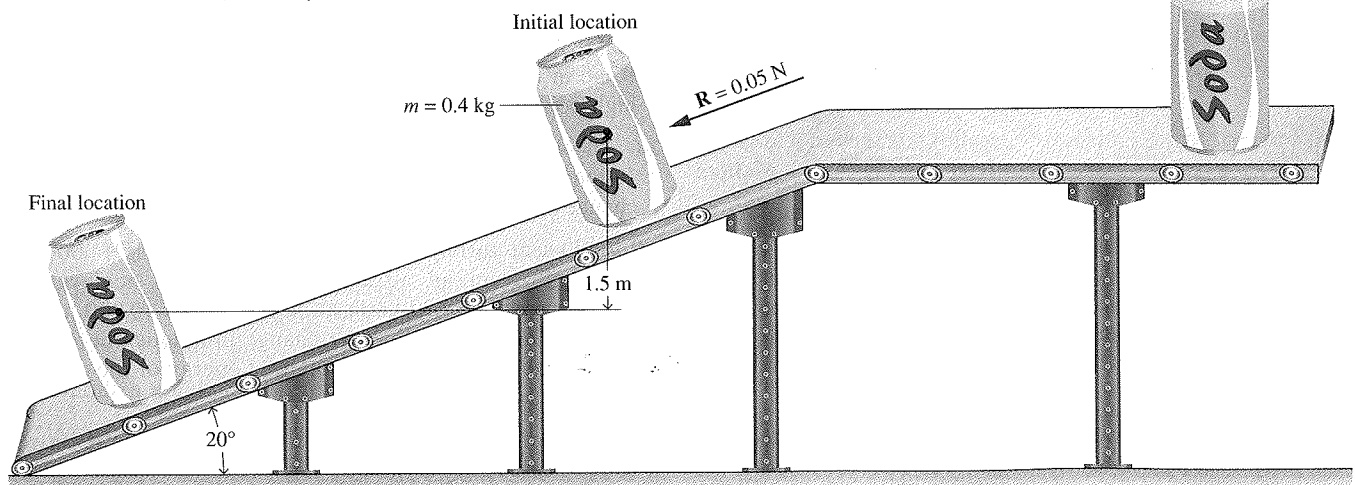

Fig. P2.15

Evaluating Work

2.18 An object initially at an elevation of 5 m relative to Earth's surface with a velocity of 50 m/s is acted on by an applied force \mathbf{R} and moves along a path. Its final elevation is 20 m and its velocity is 100 m/s. The acceleration of gravity is 9.81 m/s^2 . Determine the work done on the object by the applied force, in kJ.

2.19 An object of mass 10 kg, initially at rest, experiences a constant horizontal acceleration of 4 m/s^2 due to the action of a resultant force applied for 20 s. Determine the total amount of energy transfer by work, in kJ.

2.20 An object initially at rest experiences a constant horizontal acceleration due to the action of a resultant force applied for 10 s. The work of the resultant force is 10 Btu. The mass of the object is 55 lb. Determine the constant horizontal acceleration in ft/s^2 .

2.21 The drag force, F_d , imposed by the surrounding air on a vehicle moving with velocity V is given by

$$F_d = C_d A \frac{1}{2} \rho V^2$$

where C_d is a constant called the drag coefficient, A is the projected frontal area of the vehicle, and ρ is the air density. Determine the power, in hp, required to overcome aerodynamic drag for an automobile moving at (a) 25 miles per hour, (b) 70 miles per hour. Assume $C_d = 0.28$, $A = 25 \text{ ft}^2$, and $\rho = 0.075 \text{ lb/ft}^3$.

2.22 A major force opposing the motion of a vehicle is the rolling resistance of the tires, F_r , given by

$$F_r = fW$$

where f is a constant called the rolling resistance coefficient and W is the vehicle weight. Determine the power, in kW, required to overcome rolling resistance for a truck weighing 322.5 kN that is moving at 110 km/h. Let $f = 0.0069$.

2.23 The two major forces opposing the motion of a vehicle moving on a level road are the rolling resistance of the tires, F_r , and the aerodynamic drag force of the air flowing around the vehicle, F_d , given respectively by

$$F_r = fW, \quad F_d = C_d A \frac{1}{2} \rho V^2$$

where f and C_d are constants known as the rolling resistance coefficient and drag coefficient, respectively, W and A are the vehicle weight and projected frontal area, respectively, V is the vehicle velocity, and ρ is the air density. For a passenger car with $W = 3040 \text{ lbf}$, $A = 6.24 \text{ ft}^2$, and $C_d = 0.25$, and when $f = 0.02$ and $\rho = 0.08 \text{ lb/ft}^3$

(a) determine the power required, in hp, to overcome rolling resistance and aerodynamic drag when V is 55 mi/h.

(b) plot versus vehicle velocity ranging from 0 to 75 mi/h (i) the power to overcome rolling resistance, (ii) the power to overcome aerodynamic drag, and (iii) the total power, all in hp.

What implication for vehicle fuel economy can be deduced from the results of part (b)?

2.24 Measured data for pressure versus volume during the compression of a refrigerant within the cylinder of a

refrigeration compressor are given in the table below. Using data from the table, complete the following:

(a) Determine a value of n such that the data are fit by an equation of the form $pV^n = \text{constant}$.

(b) Evaluate analytically the work done on the refrigerant, in Btu, using Eq. 2.17 along with the result of part (a).

(c) Using graphical or numerical integration of the data, evaluate the work done on the refrigerant, in Btu.

(d) Compare the different methods for estimating the work used in parts (b) and (c). Why are they estimates?

Data Point	p (lbf/in. ²)	V (in. ³)
1	112	13.0
2	131	11.0
3	157	9.0
4	197	7.0
5	270	5.0
6	424	3.0

2.25 Measured data for pressure versus volume during the expansion of gases within the cylinder of an internal combustion engine are given in the table below. Using data from the table, complete the following:

(a) Determine a value of n such that the data are fit by an equation of the form, $pV^n = \text{constant}$.

(b) Evaluate analytically the work done by the gases, in kJ, using Eq. 2.17 along with the result of part (a).

(c) Using graphical or numerical integration of the data, evaluate the work done by the gases, in kJ.

(d) Compare the different methods for estimating the work used in parts (b) and (c). Why are they estimates?

Data Point	p (bar)	V (cm ³)
1	15	300
2	12	361
3	9	459
4	6	644
5	4	903
6	2	1608

2.26 A gas in a piston-cylinder assembly undergoes a process for which the relationship between pressure and volume is $pV^2 = \text{constant}$. The initial pressure is 1 bar, the initial volume is 0.1 m^3 , and the final pressure is 9 bar. Determine (a) the final volume, in m^3 , and (b) the work for the process, in kJ.

2.27 Carbon dioxide (CO_2) gas within a piston-cylinder assembly undergoes a process from a state where $p_1 = 5 \text{ lbf/in.}^2$, $V_1 = 2.5 \text{ ft}^3$ to a state where $p_2 = 20 \text{ lbf/in.}^2$, $V_2 = 0.5 \text{ ft}^3$. The relationship between pressure and volume during the process is given by $p = 23.75 - 7.5V$, where V is in ft^3 and p is in lbf/in.^2 . Determine the work for the process, in Btu.

2.28 A gas in a piston-cylinder assembly undergoes a compression process for which the relation between pressure and volume is given by $pV^n = \text{constant}$. The initial volume is 0.1 m^3 , the final volume is 0.04 m^3 , and the final pressure is 2 bar. Determine the initial pressure, in bar, and the work for the process, in kJ, if (a) $n = 0$, (b) $n = 1$, (c) $n = 1.3$.

2.29 Nitrogen (N_2) gas within a piston-cylinder assembly undergoes a compression from $p_1 = 20 \text{ bar}$, $V_1 = 0.5 \text{ m}^3$ to

a state where $V_2 = 2.75 \text{ m}^3$. The relationship between pressure and volume during the process is $pV^{1.35} = \text{constant}$. For the N_2 , determine (a) the pressure at state 2, in bar, and (b) the work, in kJ.

2.30 Oxygen (O_2) gas within a piston-cylinder assembly undergoes an expansion from a volume $V_1 = 0.01 \text{ m}^3$ to a volume $V_2 = 0.03 \text{ m}^3$. The relationship between pressure and volume during the process is $p = AV^{-1} + B$, where $A = 0.06 \text{ bar} \cdot \text{m}^3$ and $B = 3.0 \text{ bar}$. For the O_2 , determine (a) the initial and final pressures, each in bar, and (b) the work, in kJ.

2.31 A closed system consisting of 14.5 lb of air undergoes a *polytropic* process from $p_1 = 80 \text{ lbf/in.}^2$, $v_1 = 4 \text{ ft}^3/\text{lb}$ to a final state where $p_2 = 20 \text{ lbf/in.}^2$, $v_2 = 11 \text{ ft}^3/\text{lb}$. Determine the amount of energy transfer by work, in Btu, for the process.

2.32 Air contained within a piston-cylinder assembly is slowly compressed. As shown in Fig. P2.32, during this process the pressure first varies linearly with volume and then remains constant. Determine the total work, in kJ.

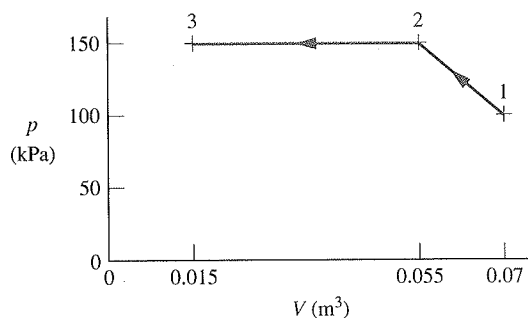

Fig. P2.32

2.33 A gas contained within a piston-cylinder assembly undergoes three processes in series:

Process 1-2: Constant volume from $p_1 = 1 \text{ bar}$, $V_1 = 4 \text{ m}^3$ to state 2, where $p_2 = 2 \text{ bar}$.

Process 2-3: Compression to $V_3 = 2 \text{ m}^3$, during which the pressure-volume relationship is $pV = \text{constant}$.

Process 3-4: Constant pressure to state 4, where $V_4 = 1 \text{ m}^3$.

Sketch the processes in series on p - V coordinates and evaluate the work for each process, in kJ.

2.34 Carbon monoxide gas (CO) contained within a piston-cylinder assembly undergoes three processes in series:

Process 1-2: Constant pressure expansion at 5 bar from $V_1 = 0.2 \text{ m}^3$ to $V_2 = 1 \text{ m}^3$.

Process 2-3: Constant volume cooling from state 2 to state 3 where $p_3 = 1 \text{ bar}$.

Process 3-1: Compression from state 3 to the initial state during which the pressure-volume relationship is $pV = \text{constant}$.

Sketch the processes in series on p - V coordinates and evaluate the work for each process, in kJ.

2.35 Air contained within a piston-cylinder assembly undergoes three processes in series:

Process 1-2: Compression during which the pressure-volume relationship is $pV = \text{constant}$ from $p_1 = 10 \text{ lbf/in.}^2$, $V_1 = 4 \text{ ft}^3$ to $p_2 = 50 \text{ lbf/in.}^2$.

Process 2-3: Constant volume from state 2 to state 3 where $p = 10 \text{ lbf/in.}^2$.

Process 3-1: Constant pressure expansion to the initial state.

Sketch the processes in series on p - V coordinates. Evaluate (a) the volume at state 2, in ft^3 , and (b) the work for each process, in Btu.

2.36 The belt sander shown in Fig. P2.36 has a belt speed of 1500 ft/min. The coefficient of friction between the sander and a plywood surface being finished is 0.2. If the downward (normal) force on the sander is 15 lbf, determine (a) the power transmitted by the belt, in Btu/s and hp, and (b) the work done in one minute of sanding, in Btu.

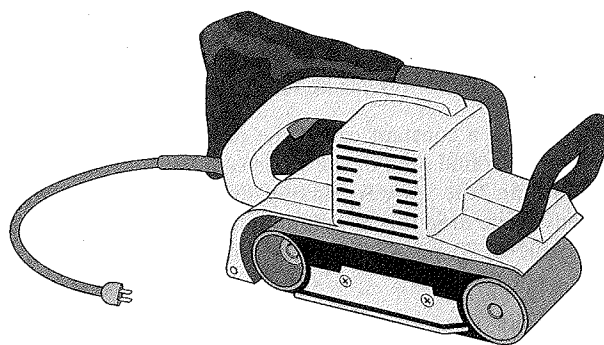

Fig. P2.36

2.37 A 0.15-m-diameter pulley turns a belt rotating the driveshaft of a power plant pump. The torque applied by the belt on the pulley is $200 \text{ N} \cdot \text{m}$, and the power transmitted is 7 kW. Determine the net force applied by the belt on the pulley, in kN, and the rotational speed of the driveshaft, in RPM.

2.38 A 10-V battery supplies a constant current of 0.5 amp to a resistance for 30 min. (a) Determine the resistance, in ohms. (b) For the battery, determine the amount of energy transfer by work, in kJ.

2.39 An electric heater draws a constant current of 6 amp, with an applied voltage of 220 V, for 24 h. Determine the instantaneous electric power provided to the heater, in kW, and the total amount of energy supplied to the heater by electrical work, in kW · h. If electric power is valued at $\$0.08/\text{kW} \cdot \text{h}$, determine the cost of operation for one day.

2.40 A car magazine article states that the power \dot{W} delivered by an automobile engine, in hp, is calculated by multiplying the torque \mathcal{T} , in $\text{ft} \cdot \text{lbf}$, by the rotational speed of the driveshaft ω , in RPM, and dividing by a constant:

$$\dot{W} = \frac{\mathcal{T}\omega}{C}$$

What is the value and units of the constant C ?

2.41 The pistons of a V-6 automobile engine develop 226 hp. If the engine driveshaft rotational speed is 4700 RPM and

the torque is $248 \text{ ft} \cdot \text{lb}$, what percentage of the developed power is transferred to the driveshaft? What accounts for the difference in power? Does an engine this size meet your transportation needs? Comment.

- 2.42 Figure P2.42 shows an object whose mass is 5 lb attached to a rope wound around a pulley. The radius of the pulley is 3 in . If the mass falls at a constant velocity of 5 ft/s , determine the power transmitted to the pulley, in hp , and the rotational speed of the shaft, in revolutions per minute (RPM). The acceleration of gravity is 32.2 ft/s^2 .

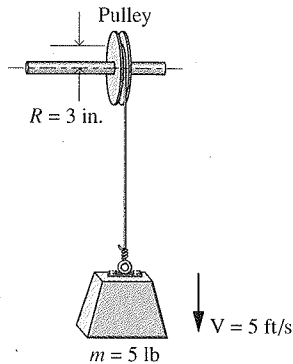

Fig. P2.42

- 2.43 As shown in Fig. P2.43, a steel wire suspended vertically having a cross-sectional area A and an initial length x_0 is stretched by a downward force F applied to the end of the wire. The normal stress in the wire varies linearly according to $\sigma = C\varepsilon$, where ε is the strain, given by $\varepsilon = (x - x_0)/x_0$, and x is the stretched length of the wire. C is a material constant (Young's modulus). Assuming the cross-sectional area remains constant,

- obtain an expression for the work done on the wire.
- evaluate the work done on the wire, in $\text{ft} \cdot \text{lb}$, and the magnitude of the downward force, in lb , if $x_0 = 10 \text{ ft}$, $x = 10.01 \text{ ft}$, $A = 0.1 \text{ in}^2$, and $C = 2.5 \times 10^7 \text{ lbf/in}^2$.

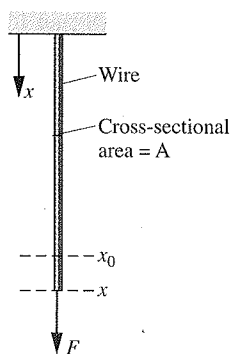

Fig. P2.43

- 2.44 A soap film is suspended on a wire frame, as shown in Fig. 2.10. The movable wire is displaced by an applied force F . If the surface tension remains constant,

- obtain an expression for the work done in stretching the film in terms of the surface tension τ , length ℓ , and a finite displacement Δx .
- evaluate the work done, in J , if $\ell = 5 \text{ cm}$, $\Delta x = 0.5 \text{ cm}$, and $\tau = 25 \times 10^{-5} \text{ N/cm}$.

- 2.45 As shown in Fig. P2.45, a spring having an initial unstretched length of ℓ_0 is stretched by a force F applied at its end. The stretched length is ℓ . By Hooke's law, the force is linearly related to the spring extension by $F = k(\ell - \ell_0)$ where k is the stiffness. If stiffness is constant,

- obtain an expression for the work done in changing the spring's length from ℓ_1 to ℓ_2 .
- evaluate the work done, in J , if $\ell_0 = 3 \text{ cm}$, $\ell_1 = 6 \text{ cm}$, $\ell_2 = 10 \text{ cm}$, and the stiffness is $k = 10^4 \text{ N/m}$.

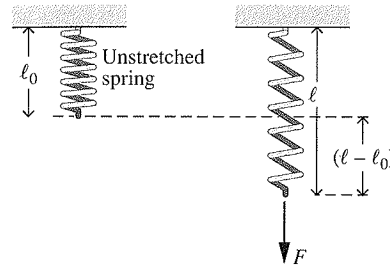

Fig. P2.45

Evaluating Heat Transfer

- 2.46 A fan forces air over a computer circuit board with surface area of 70 cm^2 to avoid overheating. The air temperature is 300 K while the circuit board surface temperature is 340 K . Using data from Table 2.1, determine the largest and smallest heat transfer rates, in W , that might be encountered for this forced convection.

- 2.47 As shown in Fig. P2.47, the 6-in.-thick exterior wall of a building has an average thermal conductivity of $0.32 \text{ Btu/h} \cdot \text{ft} \cdot ^\circ\text{R}$. At steady state, the temperature of the wall decreases linearly from $T_1 = 70^\circ\text{F}$ on the inner surface to T_2 on the outer surface. The outside ambient air temperature is $T_0 = 25^\circ\text{F}$ and the convective heat transfer coefficient is $5.1 \text{ Btu/h} \cdot \text{ft}^2 \cdot ^\circ\text{R}$. Determine (a) the temperature T_2 in $^\circ\text{F}$, and (b) the rate of heat transfer through the wall, in Btu/h per ft^2 of surface area.

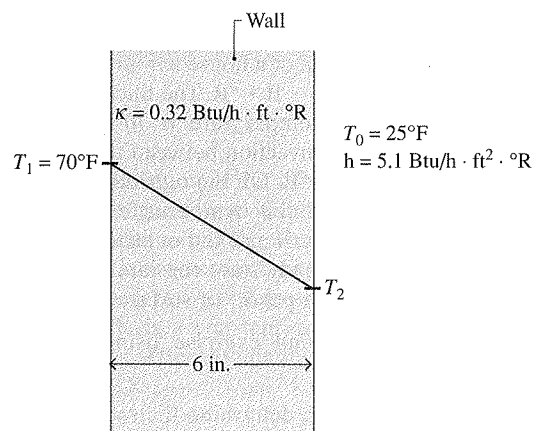

Fig. P2.47

- 2.48 As shown in Fig. P2.48, an oven wall consists of a 0.635-cm -thick layer of steel ($\kappa_s = 15.1 \text{ W/m} \cdot \text{K}$) and a layer of brick ($\kappa_b = 0.72 \text{ W/m} \cdot \text{K}$). At steady state, a temperature decrease of 0.7°C occurs over the steel layer. The inner temperature of the steel layer is 300°C . If the temperature of

the outer surface of the brick must be no greater than 40°C , determine the thickness of brick, in cm, that ensures this limit is met. What is the rate of conduction, in kW per m^2 of wall surface area?

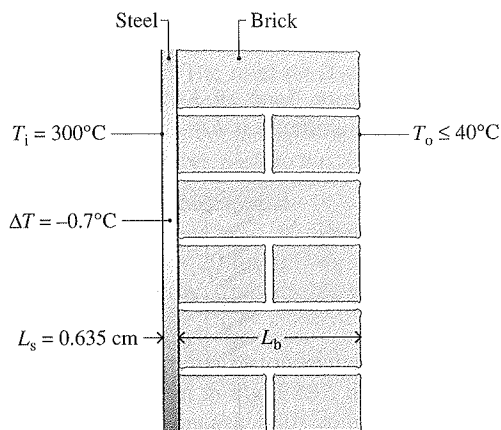

Fig. P2.48

- 2.49 A composite plane wall consists of a 12-in.-thick layer of insulating concrete block ($\kappa_c = 0.27 \text{ Btu/h} \cdot \text{ft} \cdot ^\circ\text{R}$) and a 0.625-in.-thick layer of gypsum board ($\kappa_b = 1.11 \text{ Btu/h} \cdot \text{ft} \cdot ^\circ\text{R}$). The outer surface temperature of the concrete block and gypsum board are 460°R and 560°R , respectively, and there is perfect contact at the interface between the two layers. Determine at steady state the instantaneous rate of heat transfer, in Btu/h per ft^2 of surface area, and the temperature, in $^\circ\text{R}$, at the interface between the concrete block and gypsum board.
- 2.50 A composite plane wall consists of a 3-in.-thick layer of insulation ($\kappa_s = 0.029 \text{ Btu/h} \cdot \text{ft} \cdot ^\circ\text{R}$) and a 0.75-in.-thick layer of siding ($\kappa_s = 0.058 \text{ Btu/h} \cdot \text{ft} \cdot ^\circ\text{R}$). The inner temperature of the insulation is 67°F . The outer temperature of the siding is -8°F . Determine at steady state (a) the temperature at the interface of the two layers, in $^\circ\text{F}$, and (b) the rate of heat transfer through the wall in Btu per ft^2 of surface area.
- 2.51 An insulated frame wall of a house has an average thermal conductivity of $0.04 \text{ Btu/h} \cdot \text{ft} \cdot ^\circ\text{R}$. The thickness of the wall is 6 in. The inside air temperature is 70°F , and the heat transfer coefficient for convection between the inside air and the wall is $2 \text{ Btu/h} \cdot \text{ft}^2 \cdot ^\circ\text{R}$. On the outside, the ambient air temperature is 32°F and the heat transfer coefficient for convection between the wall and the outside air is $5 \text{ Btu/h} \cdot \text{ft}^2 \cdot ^\circ\text{R}$. Determine at steady state the rate of heat transfer through the wall, in Btu/h per ft^2 of surface area.
- 2.52 Complete the following exercise using heat transfer relations:
- Referring to Fig. 2.12, determine the rate of conduction heat transfer, in W , for $\kappa = 0.07 \text{ W/m} \cdot \text{K}$, $A = 0.125 \text{ m}^2$, $T_1 = 298 \text{ K}$, $T_2 = 273 \text{ K}$.
 - Referring to Fig. 2.14, determine the rate of convection heat transfer from the surface to the air, in W , for $h = 10 \text{ W/m}^2 \cdot \text{K}$, $A = 0.125 \text{ m}^2$, $T_b = 305 \text{ K}$, $T_f = 298 \text{ K}$.
- 2.53 At steady state, a spherical interplanetary electronics-laden probe having a diameter of 0.5 m transfers energy by radiation from its outer surface at a rate of 150 W . If the probe does not receive radiation from the sun or deep space, what is the surface temperature, in K ? Let $\varepsilon = 0.8$.
- 2.54 A body whose surface area is 0.5 m^2 , emissivity is 0.8 , and temperature is 150°C is placed in a large, evacuated chamber whose walls are at 25°C . What is the rate at which radiation is emitted by the surface, in W ? What is the net rate at which radiation is exchanged between the surface and the chamber walls, in W ?
- 2.55 The outer surface of the grill hood shown in Fig. P2.55 is at 47°C and the emissivity is 0.93 . The heat transfer coefficient for convection between the hood and the surroundings at 27°C is $10 \text{ W/m}^2 \cdot \text{K}$. Determine the net rate of heat transfer between the grill hood and the surroundings by convection and radiation, in kW per m^2 of surface area.

$$T_0 = 27^\circ\text{C}$$

$$h = 10 \text{ W/m}^2 \cdot \text{K}$$

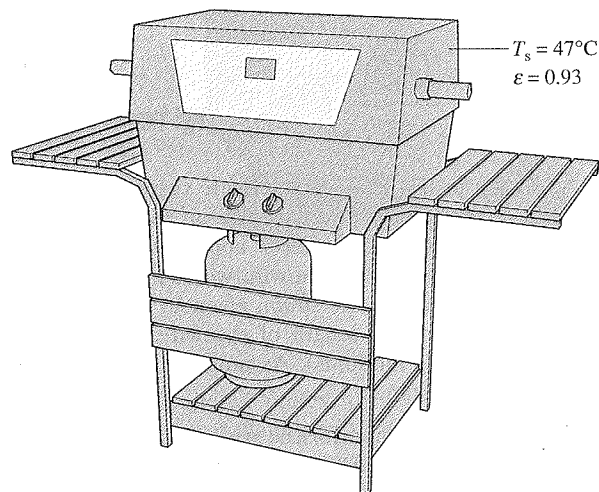

Fig. P2.55

Using the Energy Balance

2.56 Each line of the following table gives data for a process of a closed system. Each entry has the same energy units. Determine the missing entries.

Process	Q	W	E_1	E_2	ΔE
a	+50		-20		+70
b		+20		+50	+30
c		-60	+40	+60	
d	-40		+50		0
e	+50	+150		-80	

2.57 Each line of the following table gives data, in Btu , for a process of a closed system. Determine the missing table entries, in Btu .

Process	Q	W	E_1	E_2	ΔE
a	+40		+15		+15
b		+5	+7	+22	
c	-4	+10		-8	
d	-10		-10		+20
e	+3	-3	+8		

2.58 A closed system of mass 10 kg undergoes a process during which there is energy transfer by work from the system of 0.147 kJ per kg, an elevation decrease of 50 m, and an increase in velocity from 15 m/s to 30 m/s. The specific internal energy decreases by 5 kJ/kg and the acceleration of gravity is constant at 9.7 m/s². Determine the heat transfer for the process, in kJ.

2.59 As shown in Fig. P2.59, a gas contained within a piston-cylinder assembly, initially at a volume of 0.1 m³, undergoes a constant-pressure expansion at 2 bar to a final volume of 0.12 m³, while being slowly heated through the base. The change in internal energy of the gas is 0.25 kJ. The piston and cylinder walls are fabricated from heat-resistant material, and the piston moves smoothly in the cylinder. The local atmospheric pressure is 1 bar.

(a) For the gas as the system, evaluate work and heat transfer, each in kJ.

(b) For the piston as the system, evaluate work and change in potential energy, each in kJ.

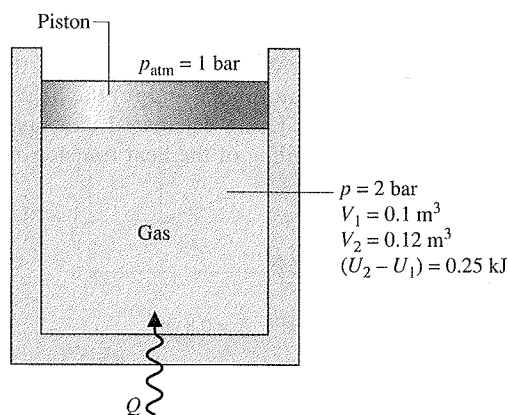

Fig. P2.59

2.60 A gas contained in a piston-cylinder assembly undergoes two processes, A and B, between the same end states, 1 and 2, where $p_1 = 1$ bar, $V_1 = 1$ m³, $U_1 = 400$ kJ and $p_2 = 10$ bar, $V_2 = 0.1$ m³, $U_2 = 450$ kJ:

Process A: Constant-volume process from state 1 to a pressure of 10 bar, followed by a constant-pressure process to state 2.

Process B: Process from 1 to 2 during which the pressure-volume relation is $pV = \text{constant}$.

Kinetic and potential effects can be ignored. For each of the processes A and B, (a) sketch the process on p - V coordinates, (b) evaluate the work, in kJ, and (c) evaluate the heat transfer, in kJ.

2.61 A gas contained within a piston-cylinder assembly undergoes two processes, A and B, between the same end states, 1 and 2, where $p_1 = 10$ bar, $V_1 = 0.1$ m³, $U_1 = 400$ kJ and $p_2 = 1$ bar, $V_2 = 1.0$ m³, $U_2 = 200$ kJ:

Process A: Process from 1 to 2 during which the pressure-volume relation is $pV = \text{constant}$.

Process B: Constant-volume process from state 1 to a pressure of 2 bar, followed by a linear pressure-volume process to state 2.

Kinetic and potential energy effects can be ignored. For each of the processes A and B, (a) sketch the process on p - V coordinates, (b) evaluate the work, in kJ, and (c) evaluate the heat transfer, in kJ.

2.62 An electric motor draws a current of 10 amp with a voltage of 110 V, as shown in Fig. P2.62. The output shaft develops a torque of 9.7 N · m and a rotational speed of 1000 RPM. For operation at steady state, determine for the motor

(a) the electric power required, in kW.

(b) the power developed by the output shaft, in kW.

(c) the average surface temperature, T_s , in °C, if heat transfer occurs by convection to the surroundings at $T_f = 21^\circ\text{C}$.

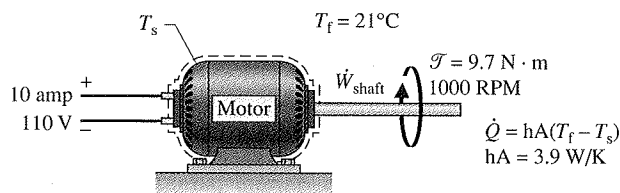

Fig. P2.62

2.63 As shown in Fig. P2.63, the outer surface of a transistor is cooled convectively by a fan-induced flow of air at a temperature of 25°C and a pressure of 1 atm. The transistor's outer surface area is 5×10^{-4} m². At steady state, the electrical power to the transistor is 3 W. Negligible heat transfer occurs through the base of the transistor: The convective heat transfer coefficient is 100 W/m² · K. Determine (a) the rate of heat transfer between the transistor and the air, in W, and (b) the temperature at the transistor's outer surface, in °C.

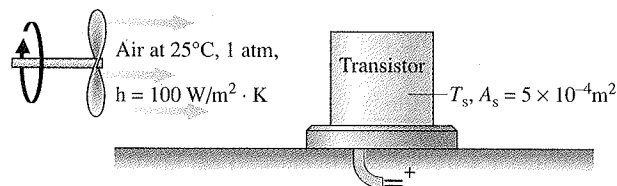

Fig. P2.63

2.64 One kg of Refrigerant 22, initially at $p_1 = 0.9$ MPa, $u_1 = 232.92$ kJ/kg, is contained within a rigid closed tank. The tank is fitted with a paddle wheel that transfers energy to the refrigerant at a constant rate of 0.1 kW. Heat transfer from the refrigerant to its surroundings occurs at a rate Kt , in kW, where K is a constant, in kW per minute, and t is time, in minutes. After 20 minutes of stirring, the refrigerant is at $p_2 = 1.2$ MPa, $u_2 = 276.67$ kJ/kg. No overall changes in kinetic or potential energy occur. (a) For the refrigerant, determine the work and heat transfer, each in kJ. (b) Determine the value of the constant K appearing in the given heat transfer relation, in kW/min.

2.65 A gas is contained in a vertical piston-cylinder assembly by a piston with a face area of 40 in.² and weight of 100 lbf. The atmosphere exerts a pressure of 14.7 lbf/in.² on top of the piston. A paddle wheel transfers 3 Btu of energy to

the gas during a process in which the elevation of the piston increases by 1 ft. The piston and cylinder are poor thermal conductors, and friction between them can be neglected. Determine the change in internal energy of the gas, in Btu.

2.66 A gas undergoes a process in a piston-cylinder assembly during which the pressure-specific volume relation is $pv^{1.2} = \text{constant}$. The mass of the gas is 0.4 lb and the following data are known: $p_1 = 160 \text{ lbf/in.}^2$, $V_1 = 1 \text{ ft}^3$, and $p_2 = 390 \text{ lbf/in.}^2$. During the process, heat transfer from the gas is 2.1 Btu. Kinetic and potential energy effects are negligible. Determine the change in specific internal energy of the gas, in Btu/lb.

2.67 Four kilograms of carbon monoxide (CO) is contained in a rigid tank with a volume of 1 m^3 . The tank is fitted with a paddle wheel that transfers energy to the CO at a constant rate of 14 W for 1 h. During the process, the specific internal energy of the carbon monoxide increases by 10 kJ/kg. If no overall changes in kinetic and potential energy occur, determine

- the specific volume at the final state, in m^3/kg .
- the energy transfer by work, in kJ.
- the energy transfer by heat transfer, in kJ, and the direction of the heat transfer.

2.68 Helium gas is contained in a closed rigid tank. An electric resistor in the tank transfers energy to the gas at a constant rate of 1 kW. Heat transfer from the gas to its surroundings occurs at a rate of $5t$ watts, where t is time, in minutes. Plot the change in energy of the helium, in kJ, for $t \geq 0$ and comment.

2.69 Steam in a piston-cylinder assembly undergoes a polytropic process. Data for the initial and final states are given in the accompanying table. Kinetic and potential energy effects are negligible. For the process, determine the work and heat transfer, each in Btu per lb of steam.

State	p (lbf/in. ²)	v (ft ³ /lb)	u (Btu/lb)
1	100	4.934	1136.2
2	40	11.04	1124.2

2.70 Air expands adiabatically in a piston-cylinder assembly from an initial state where $p_1 = 100 \text{ lbf/in.}^2$, $v_1 = 3.704 \text{ ft}^3/\text{lb}$, and $T_1 = 1000 \text{ }^\circ\text{R}$, to a final state where $p_2 = 50 \text{ lbf/in.}^2$. The process is polytropic with $n = 1.4$. The change in specific internal energy, in Btu/lb, can be expressed in terms of temperature change as $\Delta u = (0.171)(T_2 - T_1)$. Determine the final temperature, in $^\circ\text{R}$. Kinetic and potential energy effects can be neglected.

2.71 A vertical piston-cylinder assembly with a piston of mass 25 kg and having a face area of 0.005 m^2 contains air. The mass of air is 2.5 g, and initially the air occupies a volume of 2.5 liters. The atmosphere exerts a pressure of 100 kPa on the top of the piston. The volume of the air slowly decreases to 0.001 m^3 as energy with a magnitude of 1 kJ is slowly removed by heat transfer. Neglecting friction between the piston and the cylinder wall, determine the change in specific internal energy of the air, in kJ/kg. Let $g = 9.8 \text{ m/s}^2$.

2.72 Gaseous CO_2 is contained in a vertical piston-cylinder assembly by a piston of mass 50 kg and having a face area of 0.01 m^2 . The mass of the CO_2 is 4 g. The CO_2 initially occupies a volume of 0.005 m^3 and has a specific internal energy of 657 kJ/kg. The atmosphere exerts a pressure of 100 kPa on the top of the piston. Heat transfer in the amount of 1.95 kJ occurs slowly from the CO_2 to the surroundings, and the volume of the CO_2 decreases to 0.0025 m^3 . Friction between the piston and the cylinder wall can be neglected. The local acceleration of gravity is 9.81 m/s^2 . For the CO_2 determine (a) the pressure, in kPa, and (b) the final specific internal energy, in kJ/kg.

2.73 Figure P2.73 shows a gas contained in a vertical piston-cylinder assembly. A vertical shaft whose cross-sectional area is 0.8 cm^2 is attached to the top of the piston. The total mass of the piston and shaft is 25 kg. While the gas is slowly heated, the internal energy of the gas increases by 0.1 kJ, the potential energy of the piston-shaft combination increases by 0.2 kJ, and a force of 1334 N is exerted on the shaft as shown in the figure. The piston and cylinder are poor conductors, and friction between them is negligible. The local atmospheric pressure is 1 bar and $g = 9.81 \text{ m/s}^2$. Determine, (a) the work done by the shaft, (b) the work done in displacing the atmosphere, and (c) the heat transfer to the gas, all in kJ. (d) Using calculated and given data, develop a detailed accounting of the heat transfer of energy to the gas.

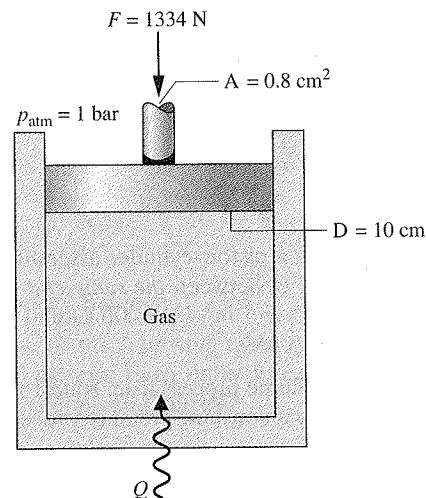

Fig. P2.73

Analyzing Thermodynamic Cycles

2.74 The following table gives data, in kJ, for a system undergoing a power cycle consisting of four processes in series. Determine, the (a) missing table entries, each in kJ, and (b) the thermal efficiency.

Process	ΔE	Q	W
1-2	-1200	0	
2-3		800	
3-4		-200	-200
4-1	400		600

2.75 The following table gives data, in Btu, for a system undergoing a power cycle consisting of four processes in series. Determine (a) the missing table entries, each in Btu, and (b) the thermal efficiency.

Process	ΔU	ΔKE	ΔPE	ΔE	Q	W
1-2	950	50	0		1000	
2-3		0	50	-450		450
3-4	-650		0	-600		0
4-1	200	-100	-50		0	

2.76 Figure P2.76 shows a power cycle executed by a gas in a piston-cylinder assembly. For process 1-2, $U_2 - U_1 = 15$ kJ. For process 3-1, $Q_{31} = 10$ kJ. There are no changes in kinetic or potential energy. Determine (a) the work for each process, in kJ, (b) the heat transfer for processes 1-2 and 2-3, each in kJ, and (c) the thermal efficiency.

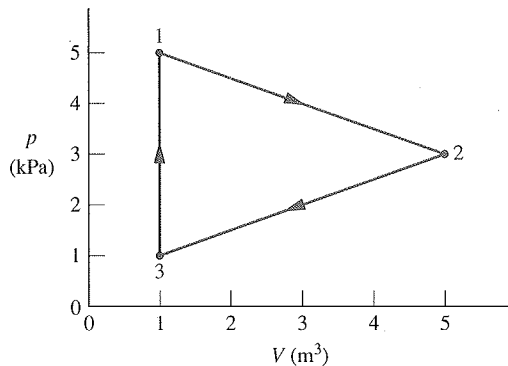

Fig. P2.76

2.77 A gas within a piston-cylinder assembly undergoes a thermodynamic cycle consisting of three processes in series, beginning at state 1 where $p_1 = 1$ bar, $V_1 = 1.5$ m³, as follows:

Process 1-2: Compression with $pV = \text{constant}$, $W_{12} = -104$ kJ, $U_1 = 512$ kJ, $U_2 = 690$ kJ.

Process 2-3: $W_{23} = 0$, $Q_{23} = -150$ kJ.

Process 3-1: $W_{31} = +50$ kJ.

There are no changes in kinetic or potential energy. (a) Determine Q_{12} , Q_{31} , and U_3 , each in kJ. (b) Can this cycle be a power cycle? Explain.

2.78 A gas within a piston-cylinder assembly undergoes a thermodynamic cycle consisting of three processes:

Process 1-2: Compression with $pV = \text{constant}$, from $p_1 = 1$ bar, $V_1 = 2$ m³ to $V_2 = 0.2$ m³, $U_2 - U_1 = 100$ kJ.

Process 2-3: Constant volume to $p_3 = p_1$.

Process 3-1: Constant-pressure and adiabatic process.

There are no significant changes in kinetic or potential energy. Determine the net work of the cycle, in kJ, and the heat transfer for process 2-3, in kJ. Is this a power cycle or a refrigeration cycle? Explain.

2.79 A gas undergoes a cycle in a piston-cylinder assembly consisting of the following three processes:

Process 1-2: Constant pressure, $p = 1.4$ bar, $V_1 = 0.028$ m³, $W_{12} = 10.5$ kJ

Process 2-3: Compression with $pV = \text{constant}$, $U_3 = U_2$

Process 3-1: Constant volume, $U_1 - U_3 = -26.4$ kJ

There are no significant changes in kinetic or potential energy.

(a) Sketch the cycle on a p - V diagram.

(b) Calculate the net work for the cycle, in kJ.

(c) Calculate the heat transfer for process 1-2, in kJ.

2.80 As shown in Fig. P2.80, a gas within a piston-cylinder assembly undergoes a thermodynamic cycle consisting of three processes in series:

Process 1-2: Compression with $U_2 = U_1$.

Process 2-3: Constant-volume cooling to $p_3 = 140$ kPa, $V_3 = 0.028$ m³.

Process 3-1: Constant-pressure expansion with $W_{31} = 10.5$ kJ.

For the cycle, $W_{\text{cycle}} = -8.3$ kJ. There are no changes in kinetic or potential energy. Determine (a) the volume at state 1, in m³, (b) the work and heat transfer for process 1-2, each in kJ. (c) Can this be a power cycle? A refrigeration cycle? Explain.

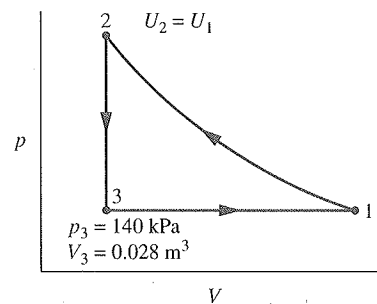

Fig. P2.80

2.81 The net work of a power cycle operating as in Fig. 2.17a is 10,000 kJ, and the thermal efficiency is 0.4. Determine the heat transfers Q_{in} and Q_{out} , each in kJ.

2.82 For a power cycle operating as shown in Fig. 2.17a, the energy transfer by heat into the cycle, Q_{in} , is 500 MJ. What is the net work developed, in MJ, if the cycle thermal efficiency is 30%? What is the value of Q_{out} , in MJ?

2.83 For a power cycle operating as in Fig. 2.17a, $Q_{\text{in}} = 17 \times 10^6$ Btu and $Q_{\text{out}} = 12 \times 10^6$ Btu. Determine W_{cycle} , in Btu, and η .

2.84 A system undergoing a power cycle requires an energy input by heat transfer of 10^4 Btu for each kW · h of net work developed. Determine the thermal efficiency.

2.85 A concentrating solar collector system, as shown in Fig. P2.85, provides energy by heat transfer to a power cycle at a rate of 2 MW. The cycle thermal efficiency is 36%. Determine the power developed by the cycle, in MW. What is the work output, in MW · h, for 4380 hours of steady-state operation? If the work is valued at \$0.08/kW · h, what is the total dollar value of the work output?

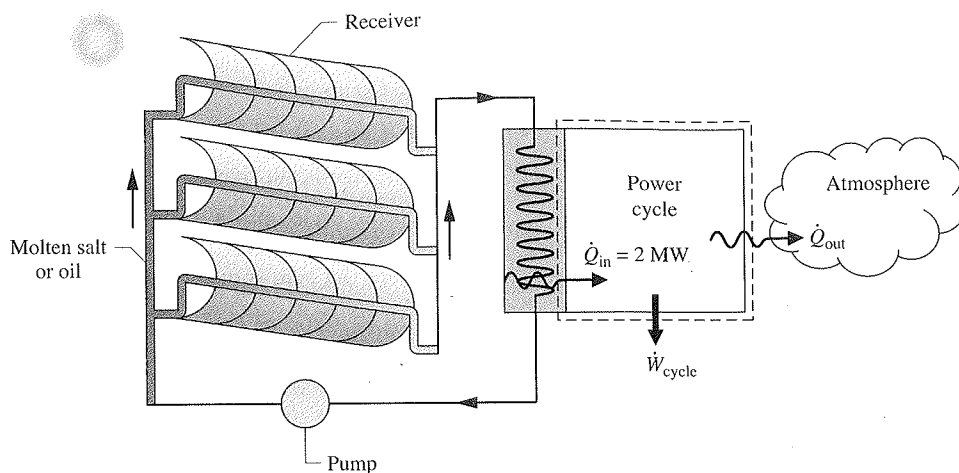
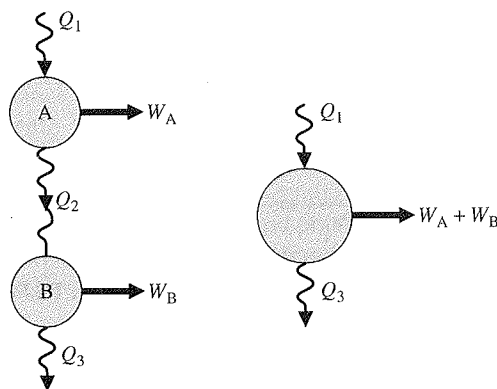

Fig. P2.85

2.86 Figure P2.86 shows two power cycles, A and B, operating in series, with the energy transfer by heat *into* cycle B equal in magnitude to the energy transfer by heat *from* cycle A. All energy transfers are positive in the directions of the arrows. Determine an expression for the thermal efficiency of an *overall* cycle consisting of cycles A and B together in terms of their individual thermal efficiencies.



(a) A and B in series (b) Overall cycle
Fig. P2.86

2.87 Shown in Fig. P2.87 is a *cogeneration* power plant operating in a thermodynamic cycle at steady state. The plant provides electricity to a community at a rate of 80 MW. The energy discharged from the power plant by heat transfer is denoted on the figure by \dot{Q}_{out} . Of this, 70 MW is provided

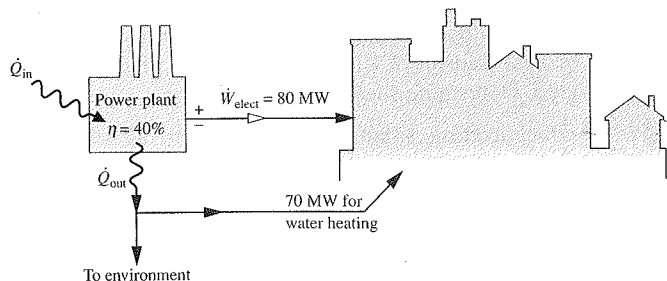

Fig. P2.87

to the community for water heating and the remainder is discarded to the environment without use. The electricity is valued at \$0.08 per kW · h. If the cycle thermal efficiency is 40%, determine the (a) rate energy is added by heat transfer, \dot{Q}_{in} , in MW, (b) rate energy is discarded to the environment, in MW, and (c) value of the electricity generated, in \$ per year.

2.88 A refrigeration cycle operating as shown in Fig. 2.17b has $Q_{out} = 1000$ Btu and $W_{cycle} = 300$ Btu. Determine the coefficient of performance for the cycle.

2.89 A refrigeration cycle operating as shown in Fig. 2.17b has a coefficient of performance $\beta = 1.8$. For the cycle, $Q_{out} = 250$ kJ. Determine Q_{in} and W_{cycle} , each in kJ.

2.90 The refrigerator shown in Fig. P2.90 steadily receives a power input of 0.15 kW while rejecting energy by heat transfer to the surroundings at a rate of 0.6 kW. Determine the rate at which energy is removed by heat transfer from the refrigerated space, in kW, and the refrigerator's coefficient of performance.

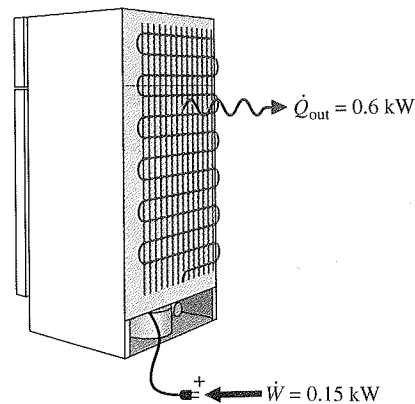

Fig. P2.90

2.91 For a refrigerator with automatic defrost and a top-mounted freezer, the annual cost of electricity is \$55. (a) Evaluating electricity at 8 cents per kW · h, determine the refrigerator's annual electricity requirement, in kW · h.

- (b) If the refrigerator's coefficient of performance is 3, determine the amount of energy removed from its refrigerated space annually, in MJ.
- 2.92 A window-mounted room air conditioner removes energy by heat transfer from a room and rejects energy by heat transfer to the outside air. For steady-state operation, the air conditioner cycle requires a power input of 0.434 kW and has a coefficient of performance of 6.22. Determine the rate that energy is removed from the room air, in kW. If electricity is valued at \$0.1/kW · h, determine the cost of operation for 24 hours of operation.
- 2.93 An air-conditioning unit with a coefficient of performance of 2.93 provides 5000 Btu/h of cooling while operating during the cooling season 8 hours per day for 125 days. If you pay 10 cents per kW · h for electricity, determine the cost, in dollars, for the cooling season.
- 2.94 A heat pump cycle operating at steady state receives energy by heat transfer from well water at 10°C and discharges energy by heat transfer to a building at the rate of 1.2×10^5 kJ/h. Over a period of 14 days, an electric meter records that 1490 kW · h of electricity is provided to the heat pump. These are the only energy transfers involved. Determine (a) the amount of energy that the heat pump receives over the 14-day period from the well water by heat transfer, in kJ, and (b) the heat pump's coefficient of performance.
- 2.95 A heat pump maintains a dwelling at 68°F. When operating steadily, the power input to the heat pump is 5 hp, and the heat pump receives energy by heat transfer from 55°F well water at a rate of 500 Btu/min.
- (a) Determine the coefficient of performance.
(b) Evaluating electricity at \$0.10 per kW · h, determine the cost of electricity in a month when the heat pump operates for 300 hours.
- 2.96 A heat pump cycle delivers energy by heat transfer to a dwelling at a rate of 40,000 Btu/h. The coefficient of performance of the cycle is 2.8.
- (a) Determine the power input to the cycle, in hp.
(b) Evaluating electricity at \$0.085 per kW · h, determine the cost of electricity during the heating season when the heat pump operates for 2000 hours.

► DESIGN & OPEN-ENDED PROBLEMS: EXPLORING ENGINEERING PRACTICE

- 2.1D Visit a local appliance store and collect data on energy requirements for different models within various classes of appliances, including but not limited to refrigerators with and without ice makers, dishwashers, and clothes washers and driers. Prepare a memorandum ranking the different models in each class on an energy-use basis together with an accompanying discussion considering retail cost and other pertinent issues.
- 2.2D Select an item that can be produced using recycled materials such as an aluminum can, a glass bottle, or a plastic or paper grocery bag. Research the materials, energy requirements, manufacturing methods, environmental impacts, and costs associated with producing the item from raw materials versus recycled materials. Write a report including at least three references.
- 2.3D Design a go-anywhere, use-anywhere wind screen for outdoor recreational and casual-living activities, including sunbathing, reading, cooking, and picnicking. The wind screen must be lightweight, portable, easy to deploy, and low cost. A key constraint is that the wind screen can be set up anywhere, including hard surfaces such as parking lots for tailgating, wood decks, brick and concrete patios, and at the beach. A cost analysis should accompany the design.
- 2.4D In living things, energy is stored in the molecule *adenosine triphosphate*, called ATP for short. ATP is said to *act like a battery*, storing energy when it is not needed and instantly releasing energy when it is required. Investigate how energy is stored and the role of ATP in biological processes. Write a report including at least three references.
- 2.5D The global reach of the Internet supports a rapid increase in consumer and business *e-commerce*. Some say e-commerce will result in net reductions in both energy use and global climate change. Using the Internet, interviews with experts, and design-group *brainstorming*, identify several major ways e-commerce can lead to such reductions. Report your findings in a memorandum having at least three references.
- 2.6D Develop a list of the most common residential cooling options in your locale. For these options and assuming a 2300-ft² home, compare installation cost, carbon footprint, and annual electricity charges. Which option is the most economical if a 12-year life is assumed? What if electricity costs twice its current cost? Prepare a poster presentation of your findings.
- 2.7D Using data from your state utility regulatory body, determine the breakdown of sources of energy for electric generation. What fraction of your state's needs is met by renewable resources such as wind, geothermal, hydroelectric, and solar energy? Present your findings in a report that summarizes current electric power sources in your state and projections in place to meet needs within the next 10 years.
- 2.8D Despite the promise of nanotechnology (see *Horizons* in Secs. 1.6 and 2.2), some say it involves risks requiring scrutiny. For instance, the tiny size of nanoparticles may allow them to evade the natural defenses of the human body, and manufacturing at the nanoscale may lead to environmental burdens and excessive energy resource use. Research the risks that accompany widespread production and deployment of nanotechnology. For each risk identified, develop policy recommendations on safeguards for consumers and the environment. Write a report with at least three references.
- 2.9D Battery disposal presents significant concerns for the environment (see *Energy and Environment*, Sec. 2.7).